

KUGELHAHN MÜLLER GmbH



KM-Hochtemperatur-Kugelhahn
DN 80 - DN 100 PN 16 - 40

Edelstahl
und Stahl

Typ: KM-X-HT-F 1/F 27
Typ: KM-A-HT-F 1/F 27

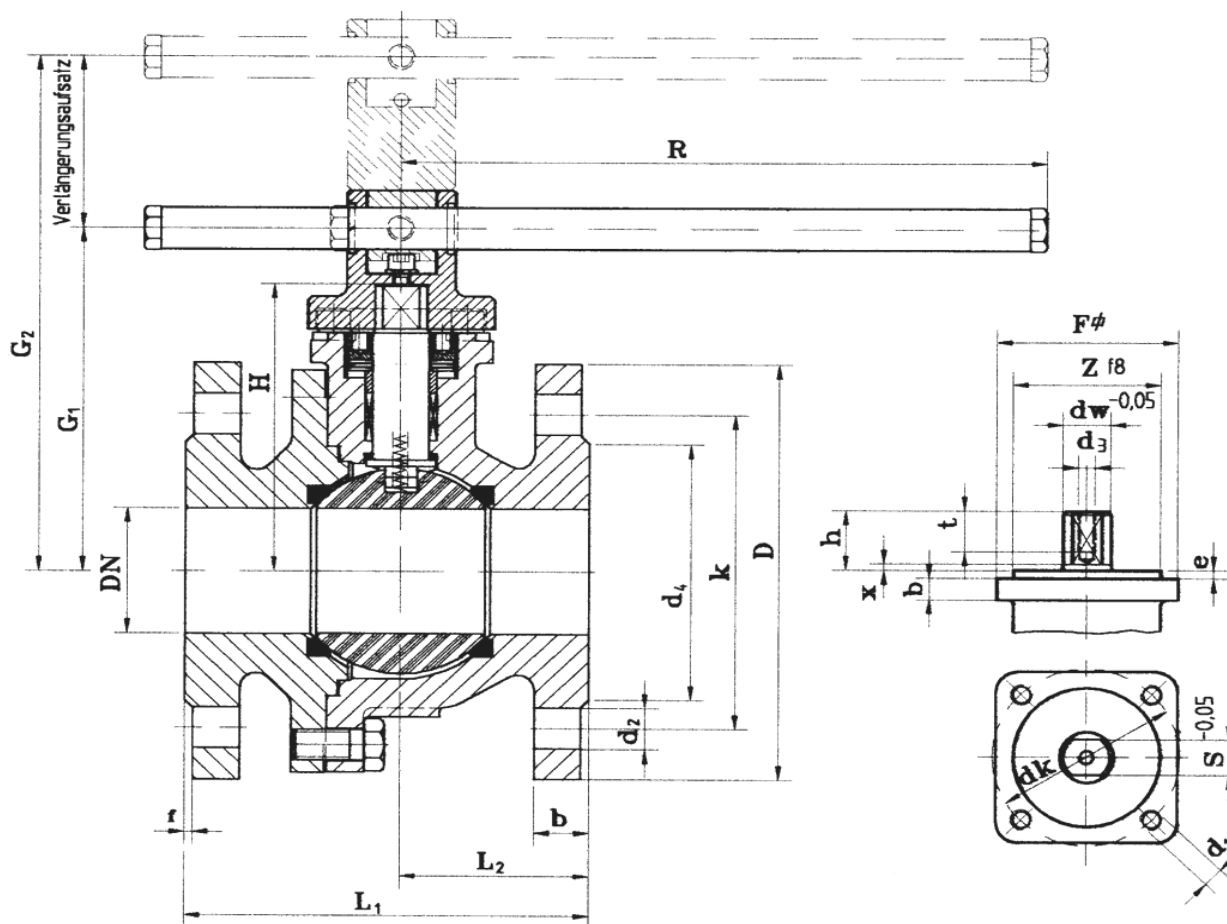

Aufbaumaße

Flansch DIN ISO 5211

DN	F	dk	d1	Z	b	h	x	e	dw	S	d3	t	DN	Größe			
80-100	96	102	M10	70	10	27	2	3	28	20	M10	15	80-100	F 10			
Baumaße							Anschlußmaße						Gewichte (kg)				
DN/PN	L1		L2	H	R	G1	G2	D	k	d4	b	f	Schrauben		Kugelhähne	Handhebel + Anschlag	
	F1	F27											St.	Ge- winde			d2
80/16	310	180	86,0	155	483	187	239	200	160	138	20	3	8	M16	18		2,3
80/40	310	180	86,0	155	483	187	239	200	160	138	24	3	8	M16	18	31,0	2,3
100/16	350	190	94,5	171	483	203	255	220	180	158	20	3	8	M16	18	38,8	2,3
100/40	350	190	94,5	171	483	203	255	235	190	162	24	3	8	M20	22	44,5	2,3

Kölnener Straße 686 • D-47807 Krefeld • Tel. +49-(0)2151-308041 • Fax +49-(0)2151-308039

Internet: <http://www.kugelhahn-mueller.de> • e-mail: info@kh-m.de